



Albury to Illabo Community Consultative Committee

Albury sub-committee

Wednesday 20 May 2026

**INLAND
RAIL** 

Acknowledgement of Country

Inland Rail acknowledges the Traditional Custodians of the land on which we meet today, and pay our respects to their Elders past and present. We extend that respect to Aboriginal and Torres Strait Islander peoples here today.

**INLAND
RAIL** 



Conflicts of interest

Garry West – Chair CCC



Agenda

- ▶ Actions from previous meeting (Nil)
- ▶ Program and project update
- ▶ Planning and Environmental update
- ▶ Community and stakeholder engagement update
- ▶ Social Performance program overview
- ▶ General Business and community feedback

Introduction/Presenters

Malcolm Clark

Project Director A2I/S2P

Susan Kay

Program Principal Advisor

Kate Hardy

Stakeholder Engagement Lead A2I

Brent Fewkes

Social Performance Principal

Trumaine Warcon

Senior First Nations Engagement Advisor A2P

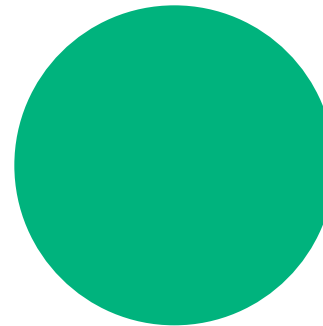
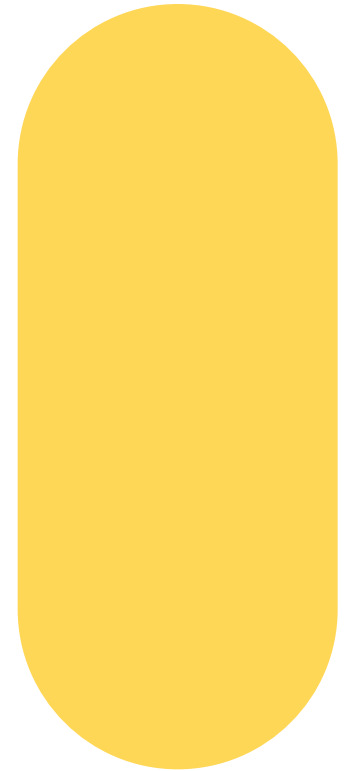



Program and Project Update

Malcolm Clark – Project Director A2I/S2P

**INLAND
RAIL** 



A2I Project Update

- Inland Rail will deliver Albury to Parkes ready for double-stacked operations by the end of 2027
- Approved project works will continue as planned
- May 2026 possession works (96 hours)
 - ▶ Wagga – Edmondson St bridge, Pearson St, Cassidy St footbridge, Mothers bridge
 - ▶ Junee – Kemp St bridge, Olympic Highway
 - ▶ Junee to Illabo
 - ▶ Albury – Murray River bridge, Albury Yard, Riverina Highway, Billy Hughes bridge
- Inland Rail new permanent CEO, Dr Sean Sweeney has been announced and will begin with Inland Rail on the 1 July 2026
- Dr Collette Burke has also been appointed as the new Chair of the Inland Rail Board



Adjacent Projects Update

Illabo to Stockinbingal (I2S)

- ▶ Minor construction works including site clearing, general earthworks & bridge preparation works are continuing
- ▶ Major construction including blasting upcoming
- ▶ Rail delivery undertaken at Illabo during May 26 possession

Stockinbingal to Parkes (S2P)

- ▶ All major works at S2P completed



A2I Program

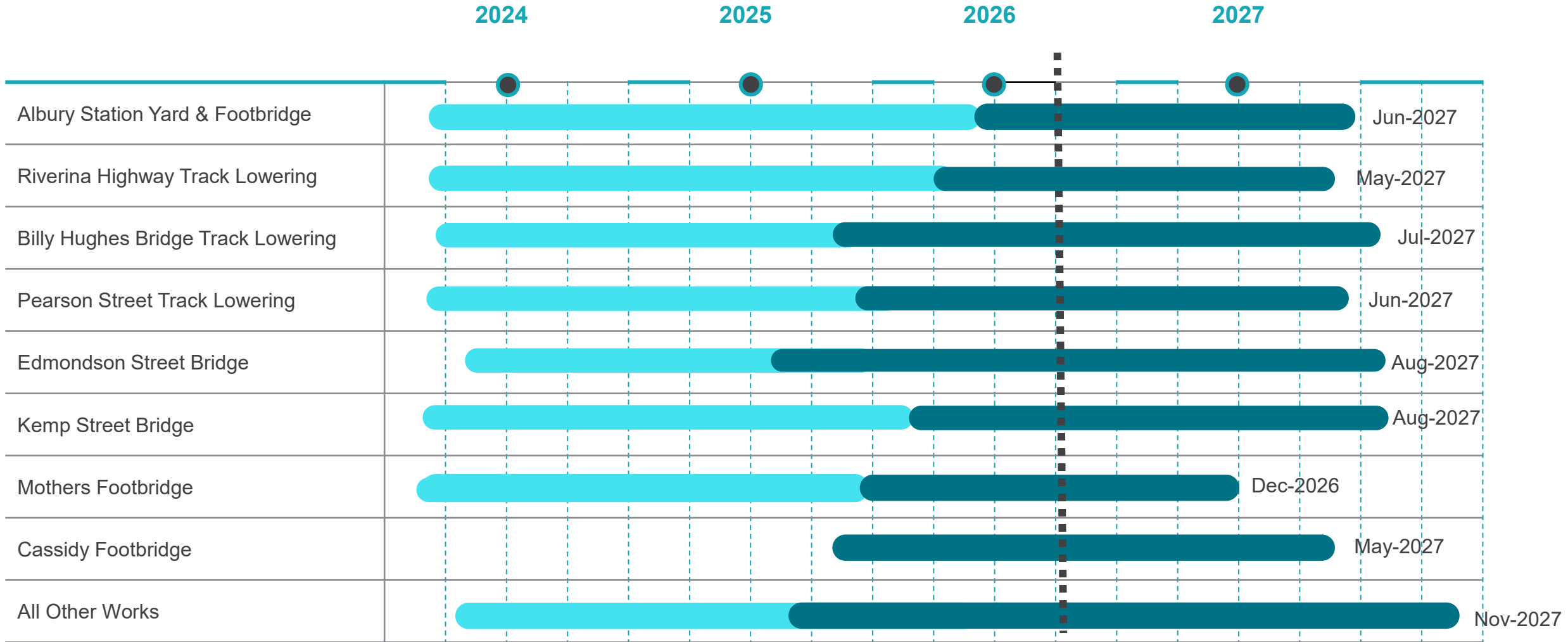

A2I Construction Progress

Clearance Sites

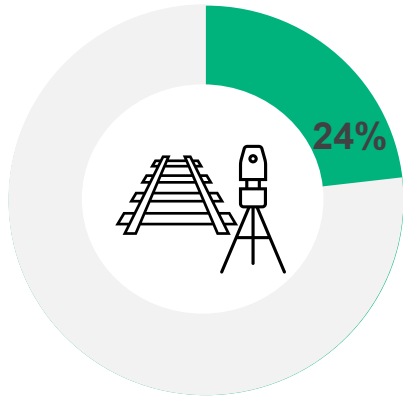

Junee to Illabo

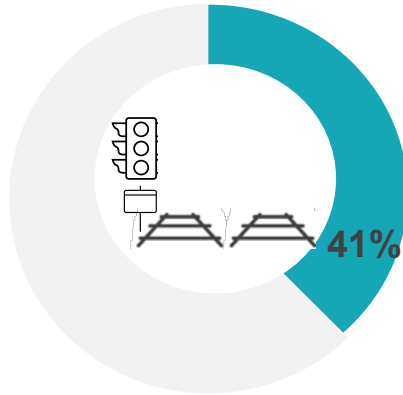

Overall Construction Progress:
32% Complete

Albury Sites

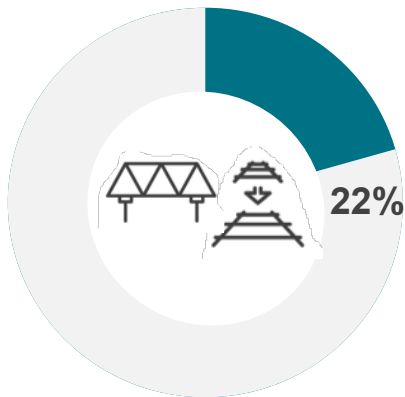

Wagga Sites

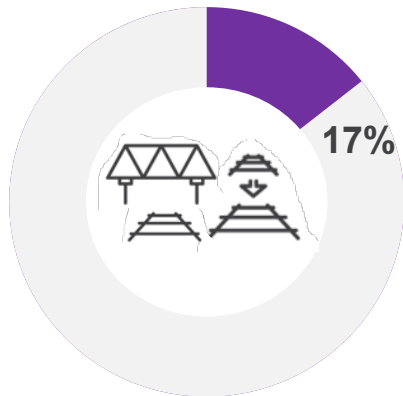

Junee Sites

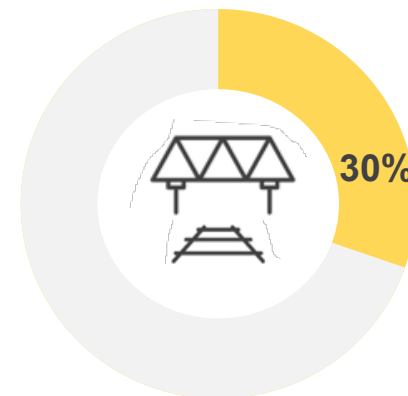

May Possession – Murray River bridge Albury



May Possession – Albury Yard



May Possession – Riverina Highway, Albury



May Possession – Billy Hughes bridge, Albury



Culcairn Footbridge

- Culcairn footbridge was removed during the December 2025 possession
- Top deck is temporarily being stored in the ARTC rail corridor as per the agreement with Greater Hume Council.
- Final decision provided to Inland Rail following the Greater Hume council meeting on 22 April 2026, with Council accepting the structure and committing to undertake the required works to transport, complete the decontamination, and place the structure in Eric Thomas Park, Culcairn.
- An Inland Rail relocation agreement is currently being prepared for execution by both parties.





**Piling works
in progress on the new
Kemp Street bridge in Junee, NSW**

Lookahead

Timing	Activity
May - July	<p>Henty</p> <ul style="list-style-type: none">• Installing signalling cables and conduits• Under bore drilling and ground excavations• Construction material and equipment deliveries <p>Billy Hughes Bridge, Albury Station, Riverina Highway and Kenilworth Street</p> <ul style="list-style-type: none">• Ground drilling and concrete piling• Drainage installation• Signalling• Earthworks and excavations
July - August	<p>Billy Hughes Bridge, Albury Station, Riverina Highway and Kenilworth Street</p> <ul style="list-style-type: none">• Retaining wall construction• Signalling• Trackwork• Installing concrete ramps at the end of Kenilworth Street
September	<p>Possession – Saturday September 12 to Tuesday September 15</p>



Planning and Environment

Susan Kay – Program Principal Advisor

**INLAND
RAIL** 



Approvals and Construction

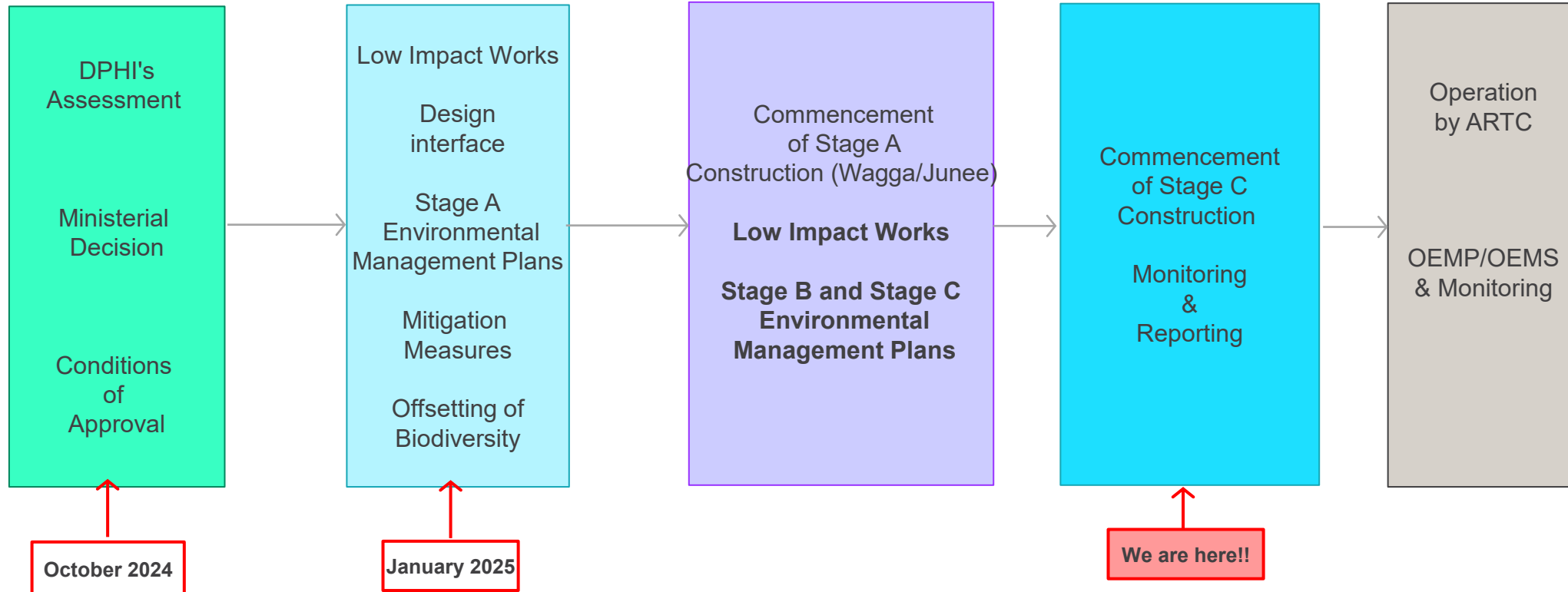
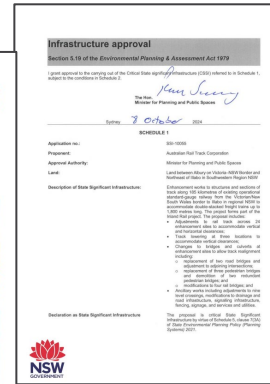
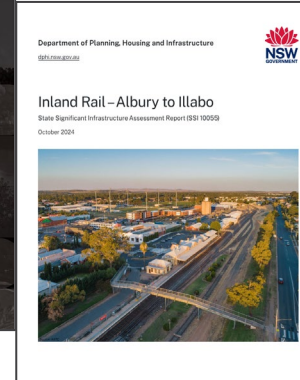
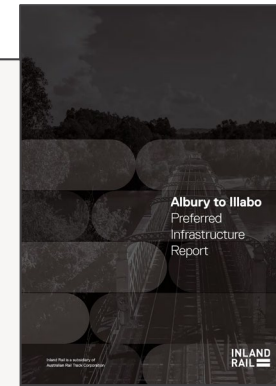
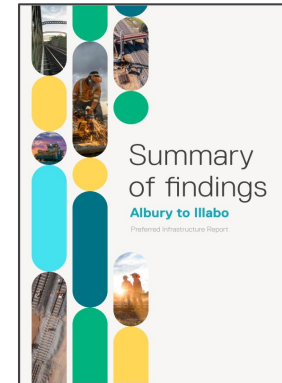

Operational Air Quality

- ▶ CoA require 12 months of air quality monitoring of wayside locomotive idling
- ▶ Prepared a Background Air Quality Monitoring Plan (CoA E4)
 - Considered a number of potential monitoring locations (power, signal location, idling frequency, impact to construction, distance from track, maintenance access)
 - Identified 4 potential locations for monitoring (Yerong Creek, The Rock, Wagga and Junee)
- ▶ Monitoring plan reviewed by EPA and submitted to DPHI
- ▶ Monitoring to commence ASAP, working through track access and power supply

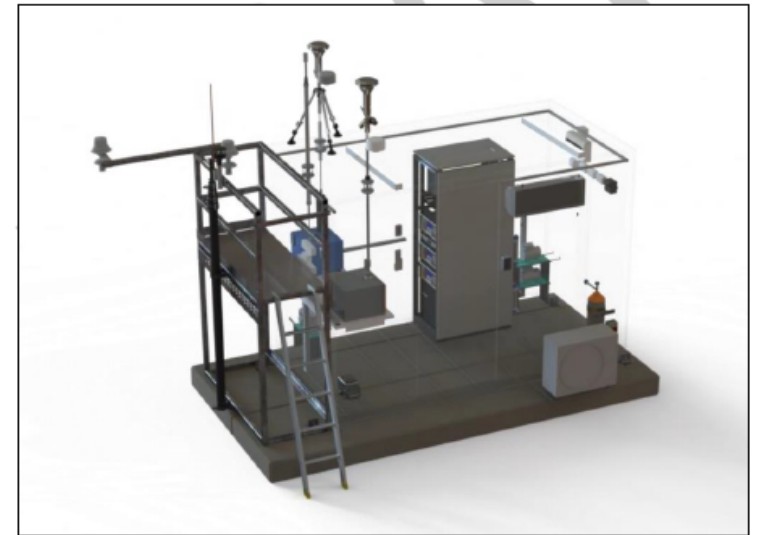
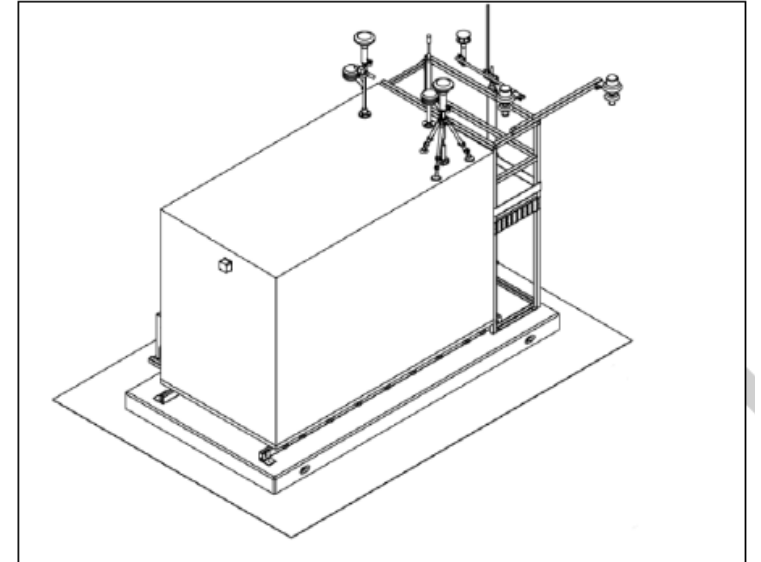

The Rock – 14m



Junee – 22m



Wagga – 12m



Frog Surveys

- ▶ Martinus undertook additional surveys following rain and warm weather at Billy Hughes Bridge:
 - 3rd March (8:30pm-9:30pm) Martinus staff using Frog ID app (frog calls)
 - 5th March Martinus and ecologist (9pm - 11pm)
- ▶ 15 species of frog were identified
- ▶ Sloanes Froglets were not audible or observed by ecologist





Community and Stakeholder engagement update

Kate Hardy – Stakeholder Engagement Lead A2I

Engagement Update

Date	Activity
March 4 and 5	STEM Challenge Days Albury
March 19	Albury Councillor briefing
April 8	Wodonga Council briefing
April 28, 29 and 30	SMART Workshops at Gerogery Public School (including Rand Public School and Walla Public School), Albury Public School and St Joseph's Culcairn
May 7	Albury and Greater Hume LEMC briefing
June 3	Greater Hume Councillor briefing
Monthly	Monitoring meetings with Council staff – Albury City Council and Greater Hume Shire Council

Successful Grants - Henty Show Society



UoN STEM Challenge Days – Albury and Wodonga



- ▶ University of Newcastle (UoN), National Science and Engineering Challenge
- ▶ March 4 – Secondary School Challenge Day
 - Winning school – Albury High School (move on to State Challenge)
 - 7 high schools in attendance
- ▶ March 5 – Primary School Discovery Day
 - Winning school – St Francis of Assisi Primary School
 - 8 primary schools in attendance
- ▶ Every school won at least 1 challenge throughout the 2 days
- ▶ Students take part in a variety of activities, including but not limited to building bridges, powering cities, designing eco-shelters, and coding.
- ▶ Volunteers from Inland Rail, Martinus and local Rotary Clubs



Social Performance program overview

Brent Fewkes – Social Performance Principal



First Nations Partnerships

- ▶ Clontarf Leadership Camp in Albury, supporting Koorringal High School, Mt Austin High School and James Fallon High School
- ▶ Upcoming launch of A2I First Nations Corridor Wide Artwork by Luke Penrith





or dreams are.

Footer

Community Benefits

Inland Rail is a national project with local benefits, generating jobs and economic opportunities for our regions and communities right across Australia.



Albury to Illabo/ Stockinbingal to Parkes

July 2023 to March 2026



Inland Rail Skills Academy

2019 – March 2026 Albury LGA



INLAND RAIL

We invest in Inland Rail alignment communities by partnering with experts to grow a local supply of businesses and future workers equipped for the 21st century.



STEM PARTNERSHIPS

15 Events held

7 Schools involved

> 2687

Students engaged in STEM activities

5% of whom are First Nations People

49% of whom are Female

139 Teachers attended



UPSKILLING LOCAL BUSINESSES

6 Supplier Capability Workshops held

0 Mentoring sessions held

108 Businesses upskilled to work on a major project

2% First Nations businesses

1 "Meet the Contractor" events held

77 Businesses attending



SKILLS TRAINING

79 Work ready individuals

5 Completed Training Competencies

63 of whom are First Nations People

of whom are Female **21**

16 Workers received training on project

8 Apprentices/ Trainees engaged



COMMUNITY GRANTS

19 Local community grants approved

\$68K Cash contributions



PROJECT WORKFORCE

94 Total workforce from LGA

0 Sustainable Jobs

38 Workers in trades

2 First Nations workers

7 Female workers

14 Young Workers (Under 25)



PROJECT PROCUREMENT

36

Businesses who have worked on the project

1 First Nations Businesses

\$10.7M

Total spend on local businesses

Inland Rail Skills Academy

2019 – March 2025 Greater Hume Shire LGA



INLAND RAIL

We invest in Inland Rail alignment communities by partnering with experts to grow a local supply of businesses and future workers equipped for the 21st century.



STEM PARTNERSHIPS

1 Events held

1 Schools involved

79 Students engaged in STEM activities

11% of whom are First Nations People

47% of whom are Female

12 Teachers attended



UPSKILLING LOCAL BUSINESSES

0 Supplier Capability Workshops held

0 Mentoring sessions held

0 Businesses upskilled to work on a major project

0% First Nations businesses

0 "Meet the Contractor" events held

0 Businesses attending



SKILLS TRAINING

0 Work ready individuals

0 Completed Training Competencies

0 of whom are First Nations People

0 of whom are Female

4 Workers received training on project

1 Apprentices/ Trainees engaged



COMMUNITY GRANTS

9 Local community grants approved

\$26K Cash contributions



PROJECT WORKFORCE

15 Total workforce from LGA

5 Sustainable Jobs

3 Workers in trades

1 First Nations workers

2 Female workers

1 Young Workers (Under 25)



PROJECT PROCUREMENT

4 Businesses who have worked on the project

0 First Nations Businesses

\$285K Total spend on local businesses



General Business and Community Feedback

Garry West – Chair CCC



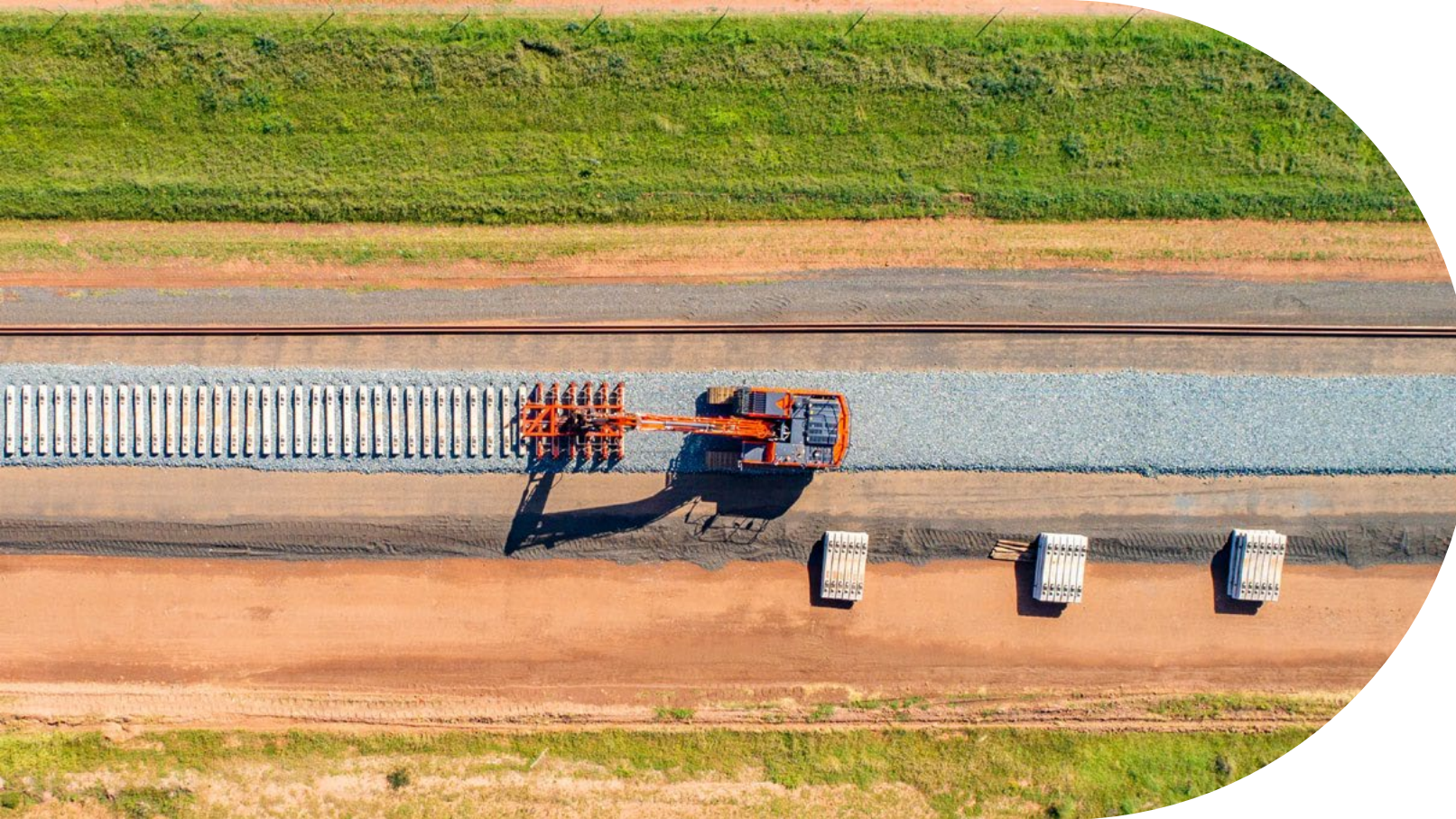

Conclusion and confirmation of actions

Garry West – Chair CCC

**INLAND
RAIL** 





Thank you

**INLAND
RAIL** 