



# Albury to Illabo Community Consultative Committee

Wagga Wagga sub-committee

Wednesday 20 May 2026

INLAND  
RAIL 

# Acknowledgement of Country

Inland Rail acknowledges the Traditional Custodians of the land on which we meet today, and pay our respects to their Elders past and present. We extend that respect to Aboriginal and Torres Strait Islander peoples here today.

**INLAND  
RAIL** 



# Conflicts of interest

Garry West – Chair CCC

**INLAND  
RAIL** 



# Agenda

- ▶ Actions from previous meeting
- ▶ Program and Project update
- ▶ Planning and Environment Update
- ▶ Community and stakeholder engagement update
- ▶ Social Performance program overview
- ▶ General Business and Community Feedback

# Actions from Previous Meetings

Action	Status
Clarify works and design planned at the Marinna bridge site	MC to update in this meeting

# Introduction/Presenters

**Malcolm Clark**

Project Director A2I/S2P

**Susan Kay**

Program Principal Advisor

**Jessica Jackson**

Stakeholder Engagement Lead A2P

**Brent Fewkes**

Social Performance Principal

**Trumaine Warcon**

Senior First Nations Engagement Advisor A2P

**INLAND  
RAIL** 

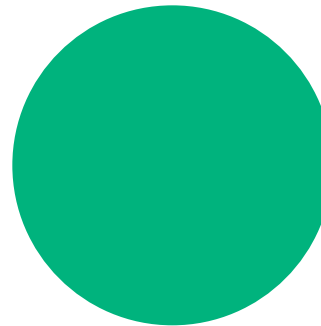



# Program and Project Update

Malcolm Clark – Project Director A2I/S2P

**INLAND  
RAIL** 



# A2I Project Update

- Inland Rail will deliver Albury to Parkes ready for double-stacked operations by the end of 2027
- Approved project works will continue as planned
- May possession works (96 hours)
  - ▶ Wagga Wagga – Edmondson St bridge, Pearson St, Cassidy St footbridge, Wagga Station Yard
  - ▶ Junee – Kemp St bridge, Olympic Highway
  - ▶ Junee to Illabo
  - ▶ Albury – Murray River bridge, Albury Yard, Riverina Highway, Billy Hughes bridge
- Inland Rail new permanent CEO, Dr Sean Sweeney has been announced and will begin with Inland Rail on the 1 July 2026
- Dr Collette Burke has also been appointed as the new Chair of the Inland Rail Board



# Adjacent Projects Update

## Illabo to Stockinbingal (I2S)

- ▶ Minor construction works including site clearing, general earthworks & bridge preparation works are continuing
- ▶ Major construction including blasting upcoming
- ▶ Rail delivery undertaken at Illabo during May 26 possession

## Stockinbingal to Parkes (S2P)

- ▶ All major works are completed



# A2I Program

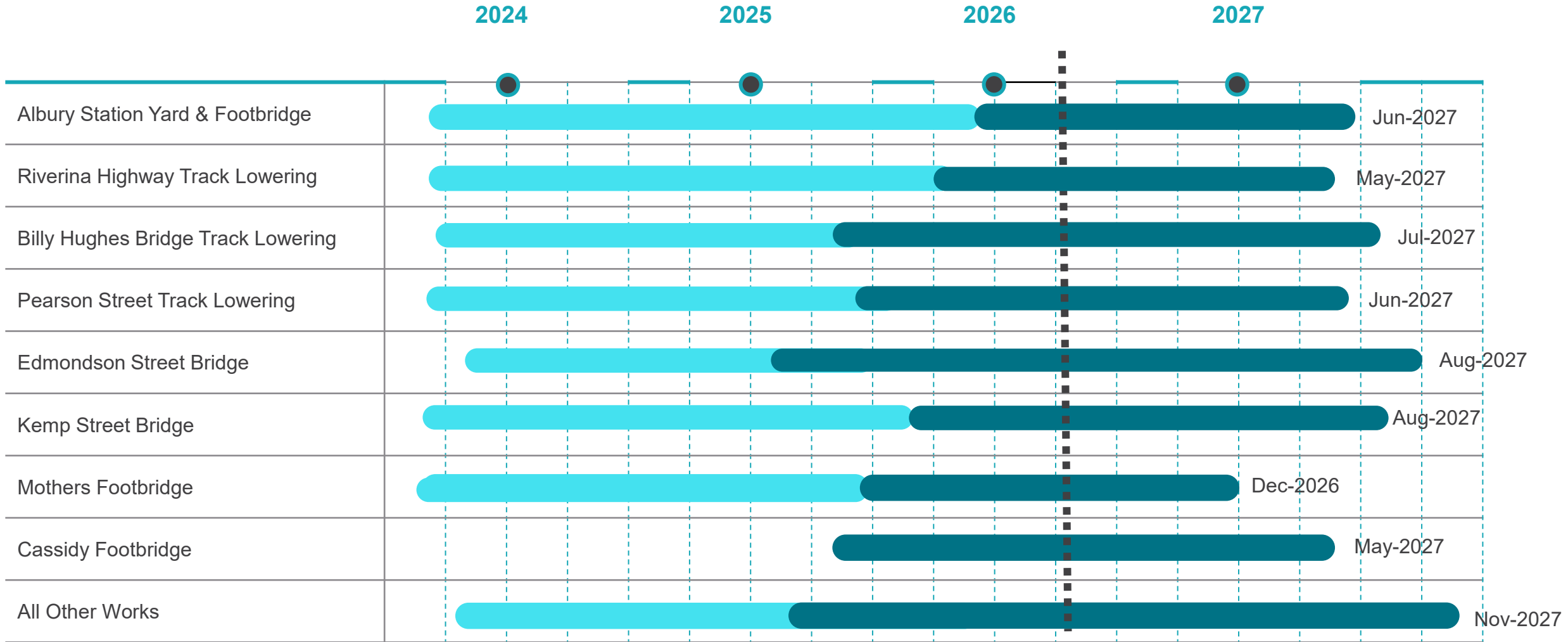

# A2I Construction Progress

## Clearance Sites

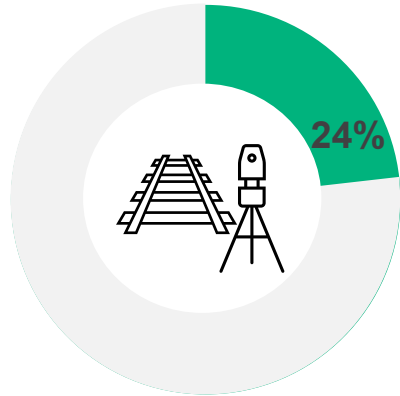

## Junee to Illabo

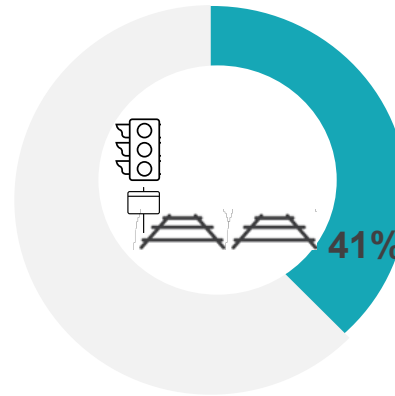

Overall Construction Progress:  
32% Complete

## Albury Sites

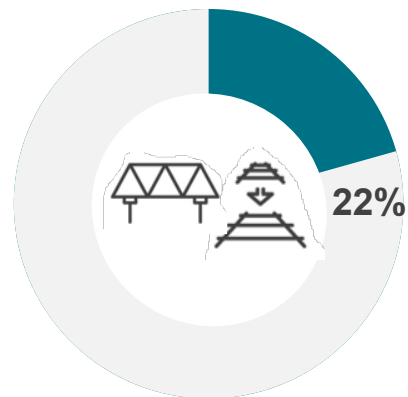

## Wagga Sites

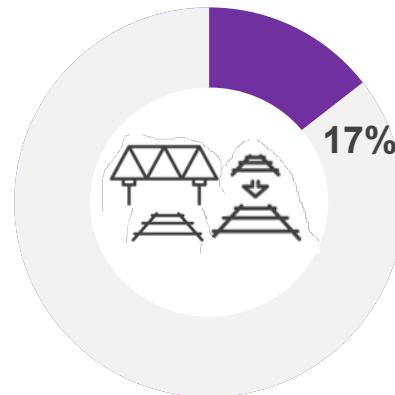

## Junee Sites

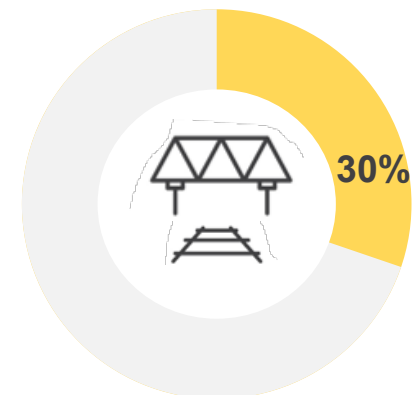



**Piling works  
in progress on the new  
Kemp Street bridge in Junee, NSW**

# May possession – Kemp St bridge, June



# May possession – Olympic Highway underbridge June

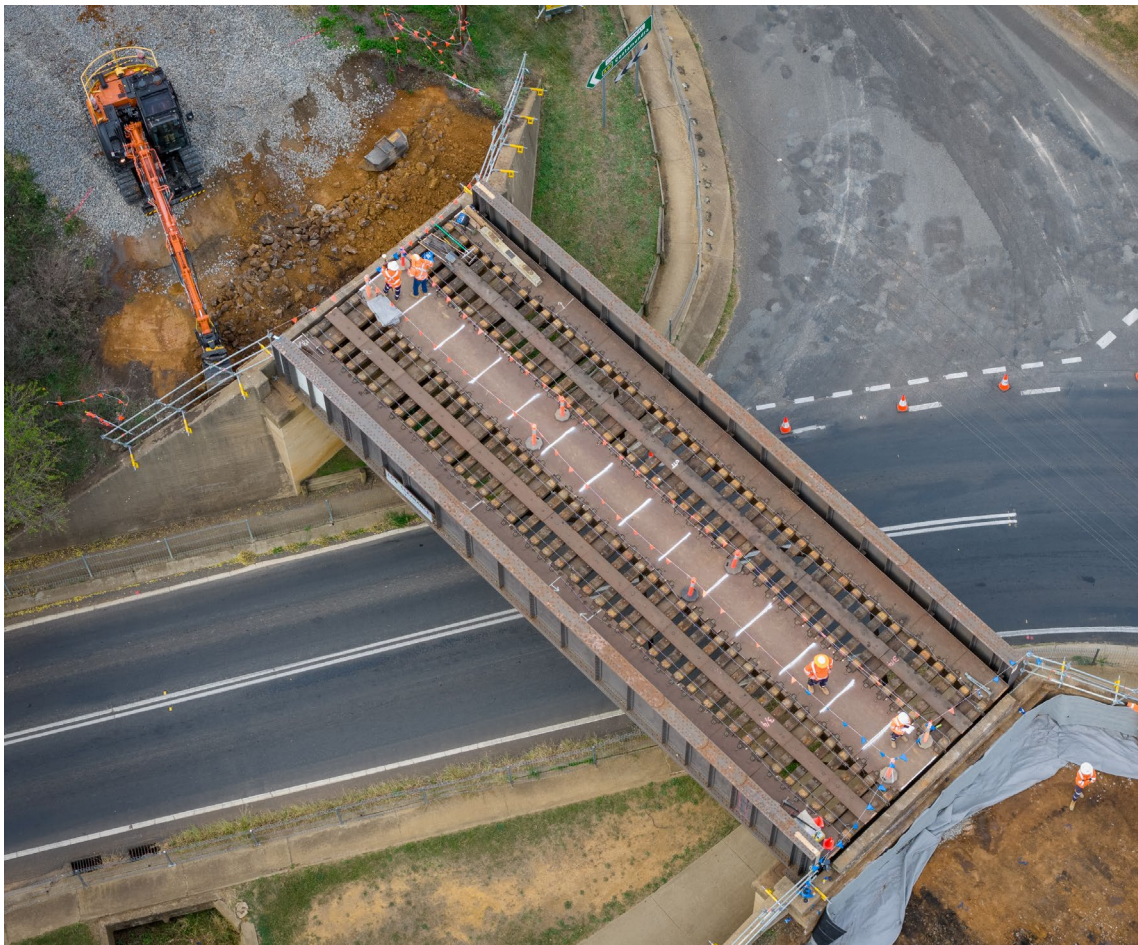

# May possession – June to Illabo



# May possession – Pearson St bridge, Wagga Wagga



# May possession – Cassidy St footbridge, Wagga Wagga



# May possession – Edmondson St bridge, Wagga Wagga



# May possession – Station Yard and Mother's footbridge, Wagga Wagga



# Junee traffic updates

**Stage 1** occurred May 11-18; Joffre St between Pretoria Ave and Olympic Hwy closed; pedestrian access in Endeavour Park remains open.

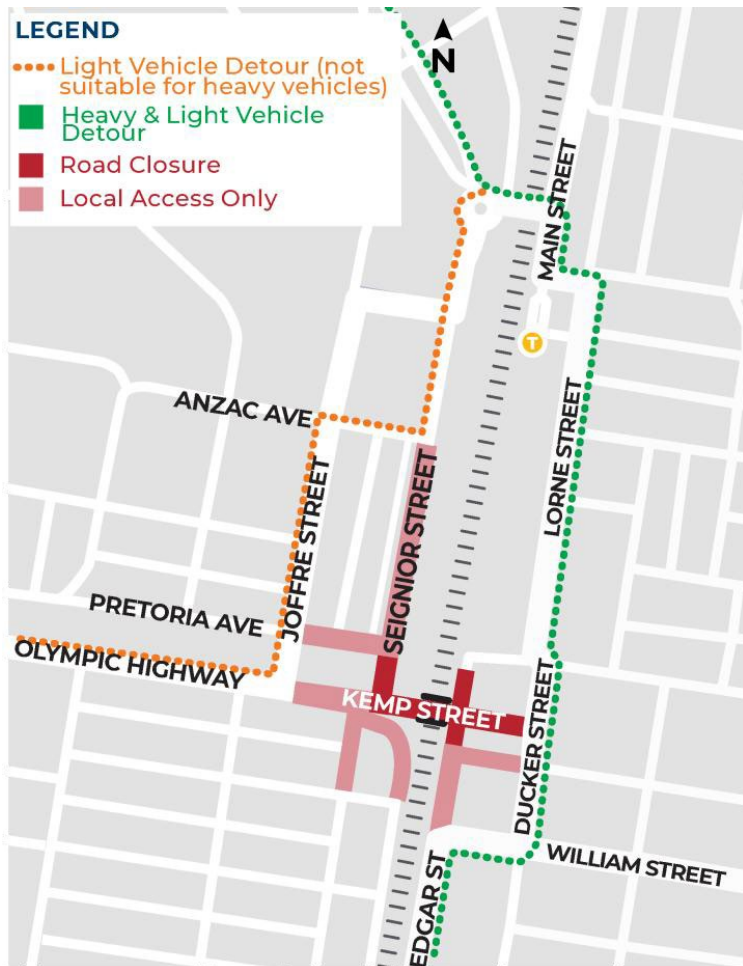

**Stage 2**  
Current – August  
In addition to stage 1 changes:  
Local traffic to access Seignior St via the service road  
Local traffic only for Olympic Hwy between Seignior and Joffre St

**Stage 3**  
August – project completion  
In addition to stage 1 and 2 changes:  
Temporary closure of access from Pretoria Ave to Seignior St service road  
Kemp St between Seignior St and Joffre St will be closed

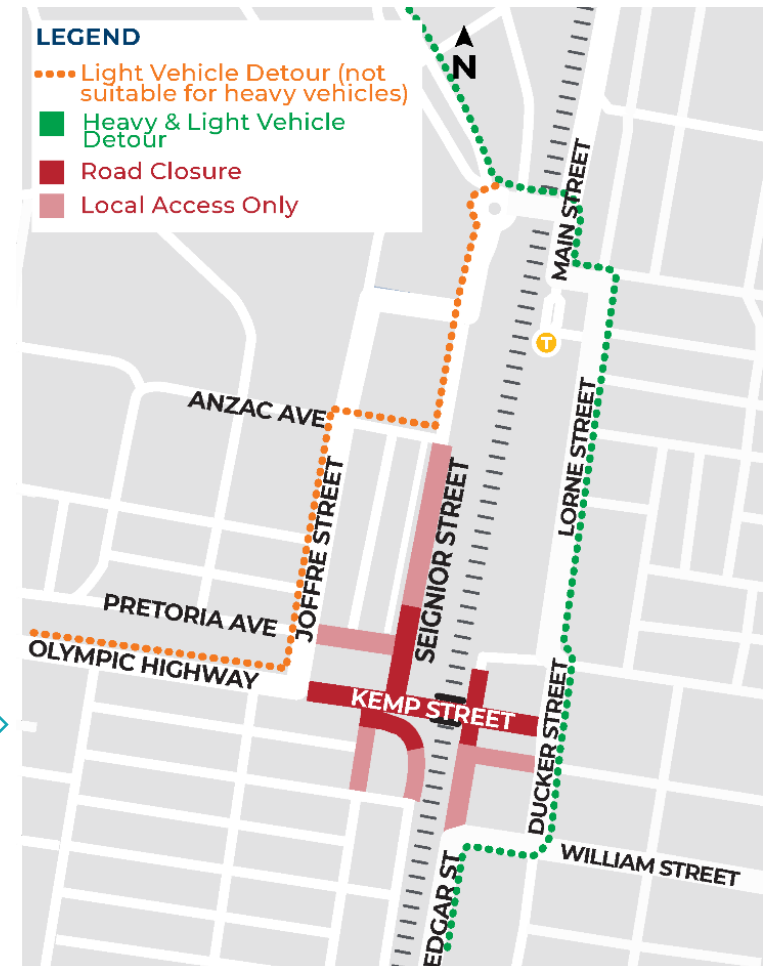

# Junee traffic updates

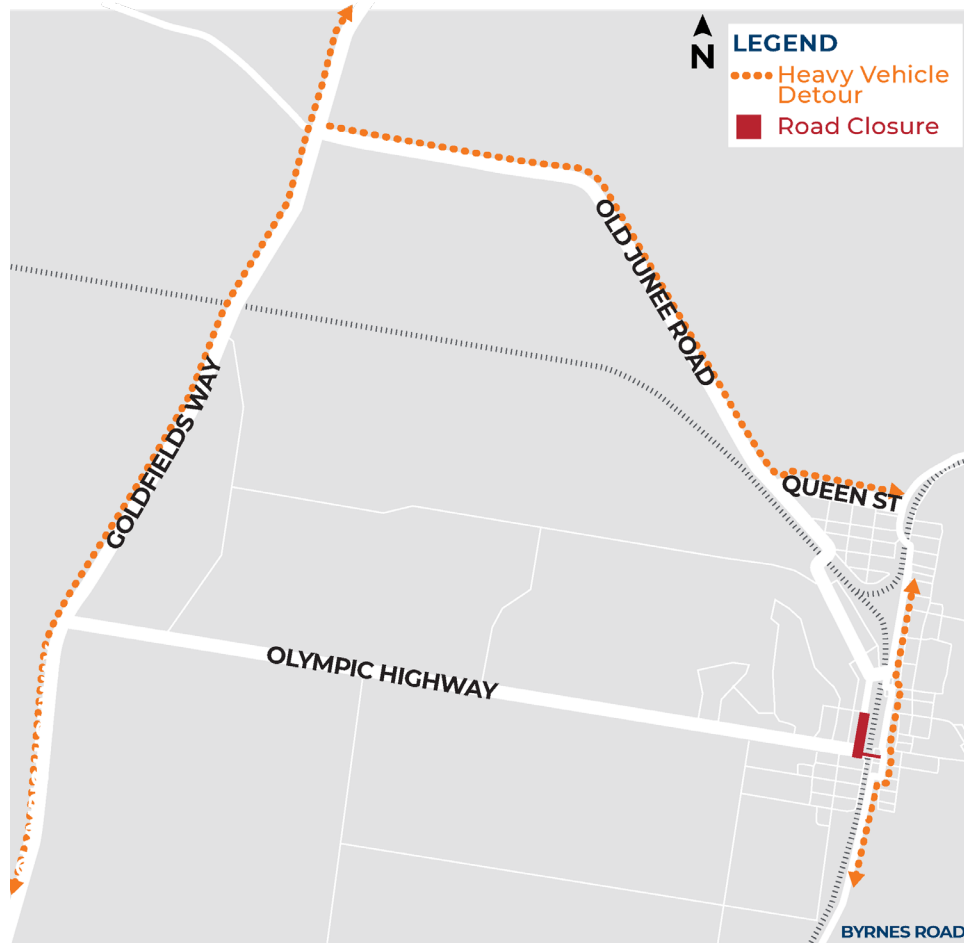

Heavy vehicle detours

- ▶ Bus services - no impacts to regular bus and school services
- ▶ Community shuttle – no interruptions until Stage 3, when the Seignior St turnaround point will be moved closer to Anzac Ave
- ▶ Additional notifications will be provided to the community as changes and closures occur in Stage 2 and 3

# Cassidy Parade temporary footbridge



- ▶ A new, temporary scaffold footbridge was installed during the May possession
- ▶ The new temporary scaffold footbridge will open on Saturday May 30
- ▶ Demolition of the existing footbridge will commence on Monday June 1, under track occupancy authority, allowing crews access to the track for specific periods
- ▶ The temporary footbridge will now be accessible via Fox St and Cassidy Prd

# Lookahead

Timing	Activity
May-June	<ul style="list-style-type: none"><li>• Pearson Street piling works</li><li>• Demolition of Cassidy Parade footbridge and opening of temporary footbridge</li><li>• Edmondson St bridge, piling works continue</li><li>• Wagga Wagga Station (Mothers) Footbridge -Construction of columns and headstocks</li><li>• Junee – staged traffic changes in place around Olympic Highway, Seigneur St, Joffre St</li><li>• Kemp St bridge – completion of permanent piling works</li></ul>
July-August	<ul style="list-style-type: none"><li>• Train diversions in place, only Wagga Wagga Station platform line in use to facilitate track construction works</li><li>• Bridgeworks continue on all key sites</li></ul>
September	<ul style="list-style-type: none"><li>• Possession – Saturday September 12 to Tuesday September 15</li><li>• Bridgeworks continue on all key site</li></ul>



# Planning and Environment

Susan Kay - Program Principal Advisor

**INLAND  
RAIL** 



# Approvals and Construction

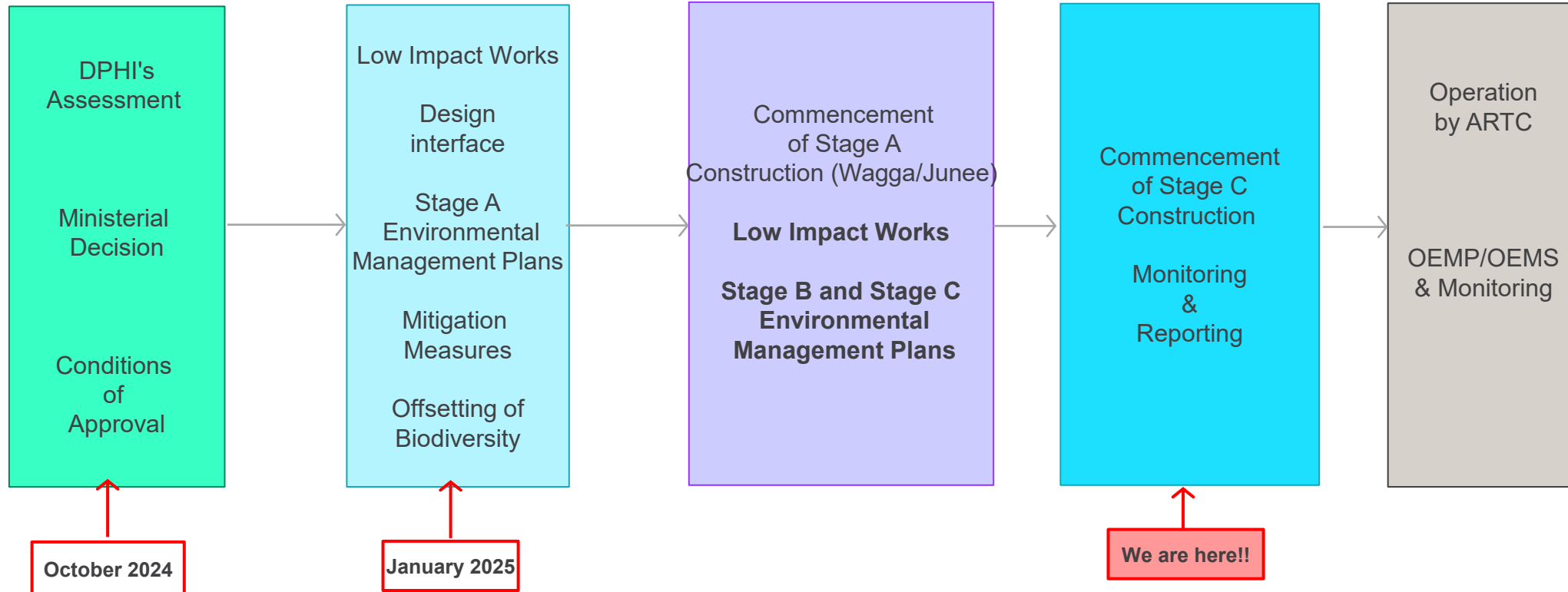
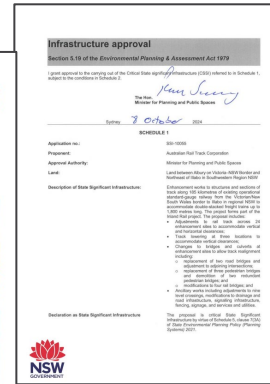
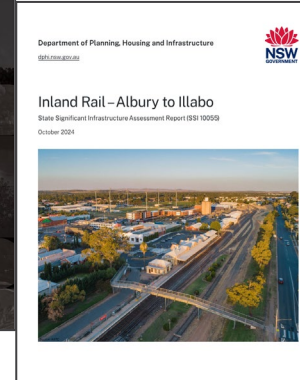
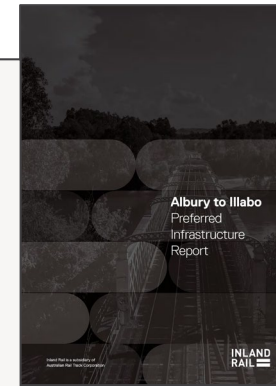
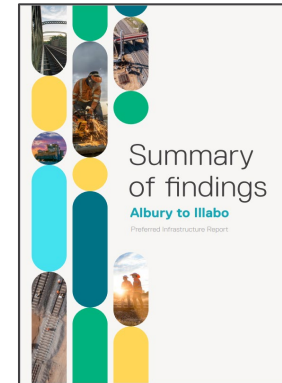

# Operational Air Quality

- ▶ CoA require 12 months of air quality monitoring of wayside locomotive idling
- ▶ Prepared a Background Air Quality Monitoring Plan (CoA E4)
  - ▶ Considered a number of potential monitoring locations (power, signal location, idling frequency, impact to construction, distance from track, maintenance access)
  - ▶ Identified 4 potential locations for monitoring (Yerong Crk, The Rock, Wagga and Junee)
- ▶ Monitoring plan reviewed by EPA and submitted to DPHI
- ▶ Monitoring to commence ASAP, working through track access and power supply

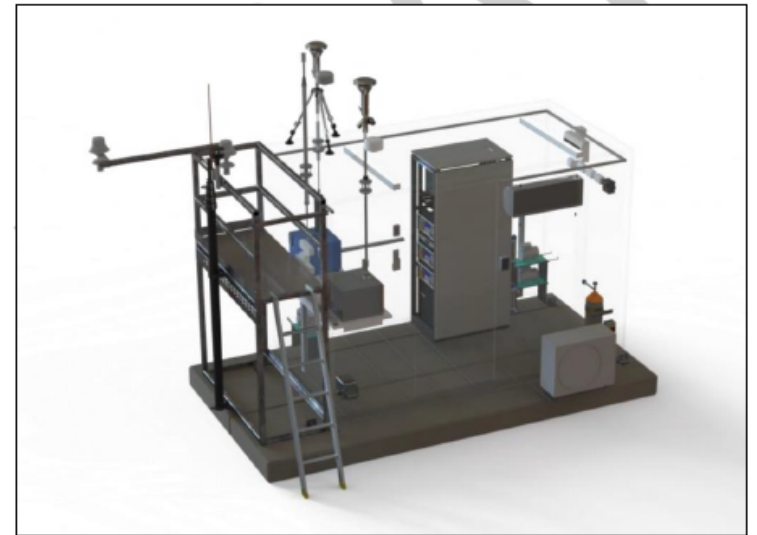
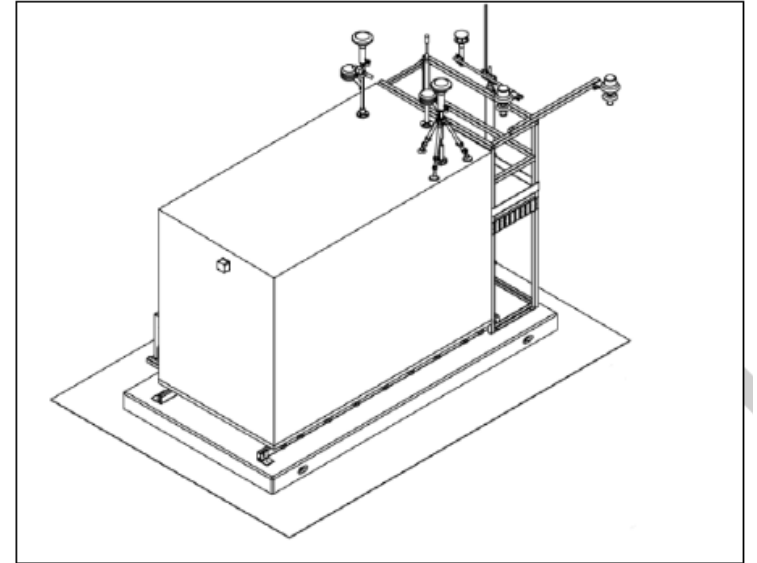

The Rock – 14m



Junee – 22m



Wagga – 12m



# Heritage – UXF Edmondson St



- ▶ Adjacent to the Best St gatehouse, within a drainage channel
- ▶ Sub-surface unexpected find in mid-March
- ▶ Likely a water cistern identified from an 1878 plan of the gate house

# Heritage - Uranquinty



- ▶ Station platform and station building foundations
- ▶ HNSW approved the test excavation methodology (6/5)
- ▶ Test excavations establish extent and nature of any subsurface archaeological deposits



# Community and Stakeholder engagement update

Jessica Jackson– Stakeholder Engagement Lead A2P



# Community Engagement

Timing	Activity
February 18	South Wagga Public School P&C
March 24 and 25	STEM Challenges (Wagga)
April 20 – May 1	Possession – alternate accommodation and respite vouchers
May 18	Lockhart Councillor briefing
May 20	Junee Lions Club
Monthly	Monitoring meetings with Council staff – Wagga Wagga City Council, Lockhart Shire Council and Junee Shire Council
6 weekly	Briefing WWCC General Manager and Mayor



# Successful Grants

- ▶ Tootool Roadside Rest Stop Committee
- ▶ Spirit of the Land Festival
- ▶ Brookdale Ball Committee
- ▶ Riverina Cancer Centre
- ▶ Carevan Wagga
- ▶ Ladysmith P&C
- ▶ Riverina Conservatorium of Music
- ▶ Wagga Swans Junior AFL and Netball Club
- ▶ Cooina Court Aged Care
- ▶ Illabo Sporting Bodies Inc.



# Local business engagement

While we rebuild Edmondson Street bridge, businesses remain open.

Find out how you can visit them on our Wagga Wagga interactive map: [+LINK](#)



**Geotarget area –**  
Wagga Wagga +40km

**Dates –**  
February 4-28

**Reach –**  
34,540

**Impressions –**  
139, 061

**Post Engagements –**  
357

**Landing page views –**  
238

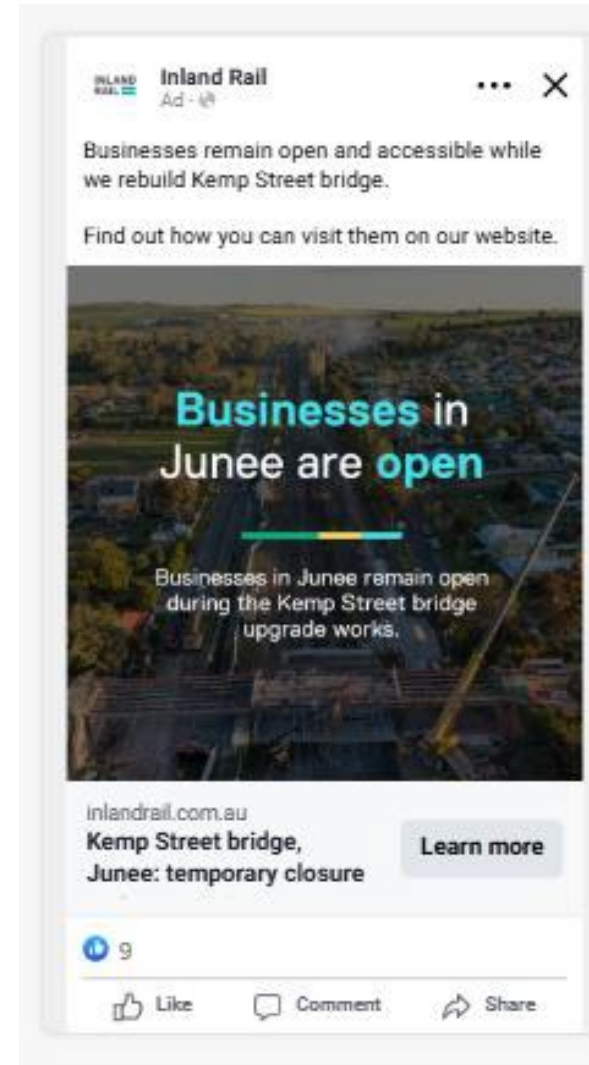

**Geotarget area –**  
Junee +20km

**Dates –**  
April 27 – May 11

**Reach –**  
32,172

**Impressions –**  
85,709

**Post Engagements –**  
140

**Landing page views –**  
123



# Social Performance program overview

Brent Fewkes – Social Performance Principal



# First Nations Partnerships

- ▶ Clontarf Leadership Camp in Albury, supporting Koorringal High School, Mt Austin High School and James Fallon High School
- ▶ Upcoming launch of A2I First Nations Corridor Wide Artwork by Luke Penrith





or dreams are.

Footer

# Community Benefits

Inland Rail is a national project with local benefits, generating jobs and economic opportunities for our regions and communities right across Australia.



## Albury to Illabo/ Stockinbingal to Parkes

July 2023 to March 2026



# Inland Rail Skills Academy

2019 – March 2026

Lockhart Shire LGA



# INLAND RAIL

We invest in Inland Rail alignment communities by partnering with experts to grow a local supply of businesses and future workers equipped for the 21<sup>st</sup> century.



## STEM PARTNERSHIPS

**2** Events held

**2** Schools involved

**72** Students engaged in STEM activities

Students engaged in STEM activities

**10%** of whom are First Nations People

**51%** of whom are Female

**10** Teachers attended



## UPSKILLING LOCAL BUSINESSES

**0** Supplier Capability Workshops held

**0** Mentoring sessions held

**0** Businesses upskilled to work on a major project

**0%** First Nations businesses

**0** "Meet the Contractor" events held

**0** Businesses attending



## SKILLS TRAINING

**0** Work ready individuals

**0** Completed Training Competencies

**0** of whom are First Nations People

**0** of whom are Female

**0** Workers received training on project

**0** Apprentices/ Trainees engaged



## COMMUNITY GRANTS

**4** Local community grants approved

**\$10K** Cash contributions



## PROJECT WORKFORCE

**5** Total workforce from LGA

**0** Sustainable Jobs

**0** Workers in trades

**0** First Nations workers

**0** Female workers

**0** Young Workers (Under 25)



## PROJECT PROCUREMENT

**0** Businesses who have worked on the project

**0** First Nations Businesses

**\$0** Total spend on local businesses

# Inland Rail Skills Academy

2019 – March 2026 Wagga Wagga City LGA



**INLAND RAIL**

We invest in Inland Rail alignment communities by partnering with experts to grow a local supply of businesses and future workers equipped for the 21<sup>st</sup> century.



## STEM PARTNERSHIPS

**24** Events held

**16** Schools involved

**3,710** Students engaged in STEM activities

Students engaged in STEM activities

**13%** of whom are First Nations People

**46%** of whom are Female

**180** Teachers attended



## UPSKILLING LOCAL BUSINESSES

**6** Supplier Capability Workshops held

**2** Mentoring sessions held

**149** Businesses upskilled to work on a major project

**5%** First Nations businesses

**2** "Meet the Contractor" events held

**154** Businesses attending



## SKILLS TRAINING

**155** Work ready individuals



**6** Completed Training Competencies

**92%** of whom are First Nations People

of whom are Female **6%**

**7** Workers received training on project

**2** Apprentices/ Trainees engaged



## COMMUNITY GRANTS

**52** Local community grants approved

**\$188K** Cash contributions



## PROJECT WORKFORCE

**159** Total workforce from LGA

**7** Sustainable Jobs

**5** Workers in trades

**25** First Nations workers

**16** Female workers

**10** Young Workers (Under 25)



## PROJECT PROCUREMENT

**86** Businesses who have worked on the project

**6** First Nations Businesses

**\$10.5M** Total spend on local businesses

# Inland Rail Skills Academy

2019 – March 2026 Junee LGA



We invest in Inland Rail alignment communities by partnering with experts to grow a local supply of businesses and future workers equipped for the 21<sup>st</sup> century.



## STEM PARTNERSHIPS

5 Events held

7 Schools involved

306

Students engaged in STEM activities

13% of whom are First Nations People

53% of whom are Female

42 Teachers attended



## UPSKILLING LOCAL BUSINESSES

2 Supplier Capability Workshops held

0 Mentoring sessions held

16 Businesses upskilled to work on a major project

2% First Nations businesses

1 "Meet the Contractor" events held

44 Businesses attending



## SKILLS TRAINING

0 Work ready individuals



0 Completed Training Competencies

0 of whom are First Nations People

0 of whom are Female

4 Workers received training on project

0 Apprentices/ Trainees engaged



## COMMUNITY GRANTS

19 Local community grants approved

\$66K

Cash contributions



## PROJECT WORKFORCE

21 Total workforce from LGA

0 Sustainable Jobs

1 Workers in trades

0 First Nations workers

2 Female workers

1 Young Workers (Under 25)



## PROJECT PROCUREMENT

6

Businesses who have worked on the project

0 First Nations Businesses

\$ 491K

Total spend on local businesses



# General Business and Community Feedback

Garry West – Chair CCC



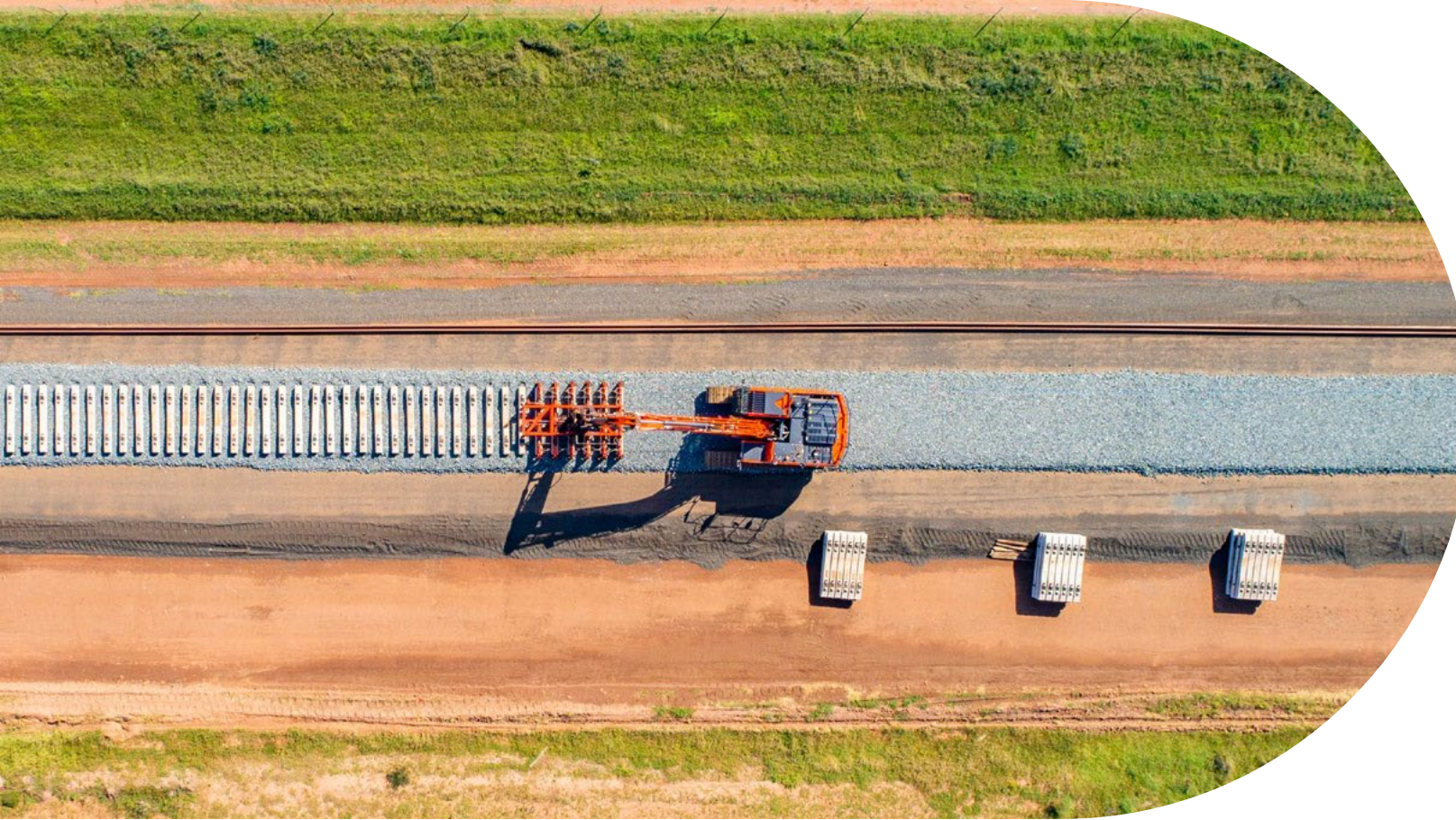

# Conclusion and confirmation of actions

Garry West – Chair CCC

**INLAND  
RAIL** 





**Thank you**

**INLAND  
RAIL** 